

# The LM-317 VOLTAGE REGULATOR

## A simple way to build a custom voltage power supply regulator.

---

Woody White, WB4QXE - woody.white@att.net - <http://woody.white.home.att.net>

---

From time to time, a stable but adjustable voltage source can be quite handy. Applications could include powering your 3 to 9 volt diskman, camcorder, H.T., etc. from a 12-15 volt source such as a battery or automotive system. In fact, the circuit can be set to supply any voltage from 3 to 38.

This article will not provide exact cookbook values for a certain regulator voltage. It is generalized, and describes what must be considered to use a LM-317.

### SUPPLY VOLTAGE & POWER DISSIPATION

The DC input voltage must be a minimum of 2 volts **higher** than the desired output voltage and absolutely no higher than 40 volts. The LM317 regulator IC is rated for up to 1.5 amps output under optimum conditions (for the TO-220 package, shown in the figure). Power dissipation in the form of heat can limit the output current to a lower value. The power dissipated can be calculated by subtracting the output voltage from the input voltage then multiplying the difference by the output current in amperes. The maximum allowable dissipation at room temperature (< 30 deg. C) is about 1.5 watts (I recommend somewhat less, or the use of a heat sink). If a suitable heat sink is used to keep the tab below 60 degrees C, the device can dissipate nearly 20 watts. If a heat sink is used, be sure to electrically isolate the tab (or heat sink) from ground or other circuitry. It is good practice is to use a bit of heat sink compound between the back of the LM-317 and the heat sink surface. For example, an input of 24 VDC and output of 9 volts yields a difference of 15 volts. If the current requirement is 0.1 amperes, then the power dissipated is 15 X 0.1, or 1.5 watts. In this case, a small heat sink would be a good idea.

### SELECTING THE RESISTOR VALUES

For proper operation the sum of R1 and R3 should be a value which draws about 8 ma. (0.008 amps) at the desired output voltage (Vo). Divide the desired output voltage by .008 to estimate the sum value of resistors 1,2, & 3. This is not extremely critical, and will provide the **maximum** resistor values. The .008 value is ideal, but can be higher (e.g. .010+) if needed to match available resistors..

$$R1 + R2 + R3 = Vo/0.008$$

The trim potentiometer value (R2) will depend on the adjustment range desired. For most applications, a potentiometer value of 10% of the sum of R1 and R2 is a good starting point. Because this article is somewhat generalized, a little experimenting with resistor values may prove necessary.

The output voltage ( $V_o$ ) is a function of the ratio of resistors  $R_1$  and  $R_3$ . Variable resistor,  $R_2$ , is used to trim (adjust) the output to the exact voltage desired. To calculate the approximate values of  $R_1$  and  $R_3$ , use the following formula:

$$V_o = 1.25 (1 + R_1/R_3)$$

Standard value resistors are available only in certain fixed value steps. The closest values to those calculated should be chosen.  $R_2$  is then adjusted to obtain the exact ratio (i.e. output voltage) required. A highly variable voltage supply can be implemented by reducing the values of  $R_1$  and  $R_3$  and increasing  $R_2$  by that amount.

### **CONSTRUCTION**

Parts layout is not critical, but for good temperature stability the proper resistor type should be used. Also, keep them as far away as practical from heat sources. Overall stability of the voltage will depend on a number of variables, but should typically be better than 0.25% after warm-up.

### **PROTECTION & STABILIZATION**

The diode ( $D_1$ ) and capacitor ( $C_2$ ) are optional. The diode protects the LM317 from reverse voltages that may arise in certain applications. The capacitor ( $C_2$ ) will ever so slightly slow the regulator transient response, but can help reduce the possibility of introduced noise when the regulator is used in a location subject to strong interfering fields. For the most simple circuit,  $R_2$  may be eliminated, connecting  $R_1$  directly to  $R_3$  and then connecting that junction to the “adjust” lead of the LM317. Available standard resistor values will, however, limit the output voltage values available.

### **CIRCUIT FIGURE**

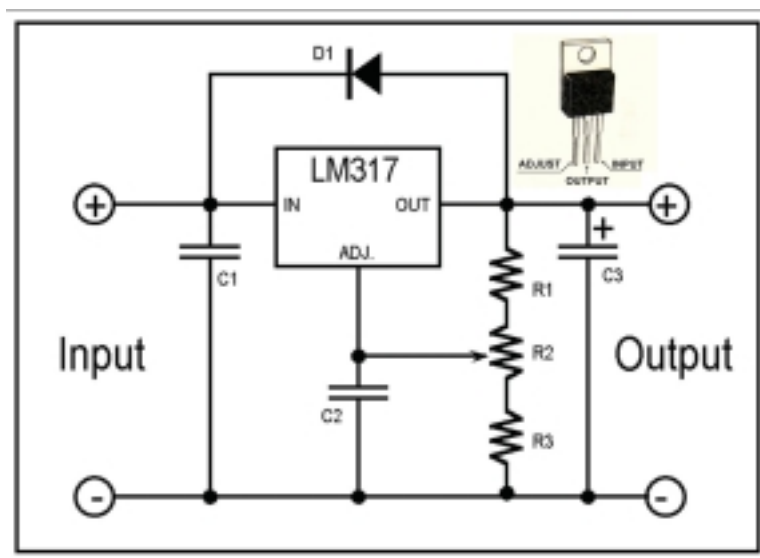

## PARTS LIST

The LM317 is limited to a maximum of 1.5 amps. Higher current devices are available which work in a similar manner. The chip package is typically different in order to handle the higher current. The LM350 can supply 3 amps and the LM338 is rated to 5 amps. Data on these devices, as well as the LM317 can be found at the National Semiconductor site below.

[http://www.national.com/catalog/AnalogRegulators\\_LinearRegulatorsStandardNPN\\_PositiveVoltageAdjustable.html](http://www.national.com/catalog/AnalogRegulators_LinearRegulatorsStandardNPN_PositiveVoltageAdjustable.html)

Most parts available at Radio Shack or by mail order suppliers (e.g. Digi-Key). Catalog numbers referenced here are from Digi-Key (<http://www.digikey.com> -or- 1-800-344-4539). I have no vested interest in either supplier.

LM317(LM317AT-ND), Adjustable positive voltage regulator, (see figure for pin-out) PT# 92448-ND

D1 1N4002, 1 Amp, 200 volt, (observe polarity when installing)  
PT# 1N4002GICT-ND

R1, R3 Exact values dependent on calculations. For best stability, precision wire wound resistors are specified. Other types may be substituted if precision stability is not a concern. PT# SC1A(value)-ND or SC3D(value)-ND

R2 Trimmer potentiometer, Bourns series 3059P, Value dependent on desired adjustment range and  $V_o$  (see calculations).  
PT# 3059P(value)-ND. **NOTE:** An inexpensive potentiometer may be substituted with a small loss in stability and settability.

C1 0.1 uF, 50 volt minimum, monolithic ceramic PT# P4887-ND

C2 220 pF, 50 volt minimum, monolithic ceramic PT# P4804-ND

C3 2.2 uF, 50 volt, electrolytic (observe polarity when installing)  
PT# P6790-ND

PerfBoard Epoxy-Glass or phenolic board with pre-punched hole arrays. Available from Digi-Key. Manufacturers: Vector Co. or Keystone. A 4.5" x 6.5" (should be sufficient for 3 or more circuits) is PT# V1043

Heat Sink A good source for small heat sinks is a dead computer monitor. Digi-Key also carries Aavid brand heat sinks. Size will depend on heat load and ambient temperature. They also carry heat sink compound.